

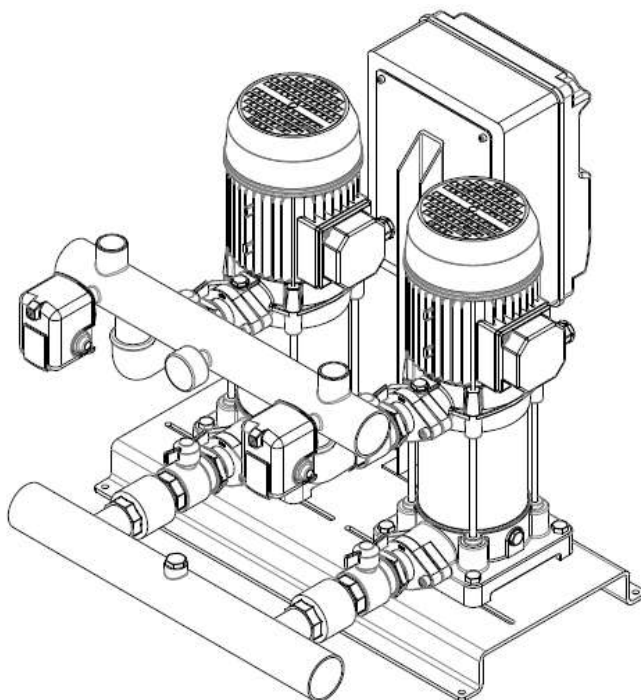

GRUPPI DI PRESSURIZZAZIONE GP E GPE

BOOSTER SETS GP AND GPE

GOUPS DE PRESSURISATION GP ET GPE



PRESENTAZIONE GENERALE

L'ampia gamma di pompe disponibili a catalogo permette a STAC di offrire ai propri Partners un'altrettanta vasta gamma di sistemi di pressurizzazione ad 1, 2 o più elettropompe. Il presente fascicolo illustra dati e caratteristiche dei sistemi a due pompe. Tutti i materiali scelti sono di primissima qualità, a partire dalla base, collettori, valvolame e quadri di controllo. I gruppi si distinguono in GP (gruppi di pressione funzionanti a velocità fissa e regolati da pressostati), GPE (gruppi di pressione funzionanti con inverter e sensori di pressione, installati in mandata) e GPV, gruppi di pressione con inverter installati a bordo motore..

Oltre alle soluzioni presenti a catalogo, STAC è in grado di realizzare gruppi di pressione secondo specifiche del Cliente, sfruttando l'ampia gamma di elettropompe a catalogo e garantendo massima flessibilità sia nelle prestazioni che nei tempi di consegna.

Per maggiori informazioni, prego consultare il nostro sito internet www.stac-ts.com, il nostro catalogo generale oppure contattate la nostra rete vendita.

GENERAL PRESENTATION

The wide range of pumps available in the catalogue allows STAC to offer to its Partners an equally wide range of pressure sets with 1, 2 or more electric pumps. This dossier illustrates the data and characteristics of the systems with the highest circulation. All the materials chosen are of the highest quality, starting from the base, manifolds, valves and control panels. The groups are divided into GP (pressure sets at fixed speed operating with pressure switches), GPE (pressure groups operating with inverter and pressure sensors, installed in the delivery) and GPV, with inverters installed on board.

In addition to the solutions in this leaflet, STAC is able to create pressure groups according to customer's specifications, taking advantage of the wide range of electric pumps in the general catalogue and ensuring maximum flexibility both in terms of performance and delivery times.

For more information, please consult our website www.stac-ts.com, our general catalogue or contact our sales network.

PRÉSENTATION GÉNÉRALE

La large gamme de pompes disponibles dans le catalogue permet à STAC d'offrir à ses partenaires une gamme tout aussi large de systèmes de pressurisation à 1, 2 ou plus électropompes. Ce dossier illustre les données et les caractéristiques des systèmes à circulation plus élevée. Tous les matériaux choisis sont de la plus haute qualité, à partir de la base, des collecteurs, des vannes et des panneaux de commande. Les groupes sont divisés en GP (groupes de pression a vitesse fixe fonctionnant avec des pressostats) GPE (groupes de pression fonctionnant avec inverter et des capteurs de pression, installés côté livraison) et GPV, avec inverter installée a bord du moteur.

En plus des solutions de cet catalogue, STAC est en mesure de créer des groupes de pression selon les spécifications du client, en profitant de la large gamme de pompes électriques du catalogue et en garantissant une flexibilité maximale en termes de performances et de délais de livraison.

Pour plus d'informations, veuillez consulter notre site Internet www.stac-ts.com, notre catalogue général ou contacter notre réseau commercial.

2	GP	E	CB/200	T	50	Ss304
N° di pompa	Gruppo di pressurizzazione	Null = pressostati / Pressure switches / pressostats	Modello pompa	M = monofase / singlephase / monophasé	50=50Hz	Opzione materiali (vedi pagina seguente)
N° of pumps	Booster set	E = inverter in quadro	Pump model	T = trifase / three-phase / triphasé	60=60Hz	Material options (please see next page)
N° de pompes	Group de pressurisation	V = inverter a bordo motore	Model de la pompe			Materiels d'execution (SVP voir page suivante)
						Null = standard Ss304 = Aisi 304 Ss316 = Aisi 316

COMPONENTI E MATERIALI / COMPONENTS AND MATERIALS / COMPONENTS ET MATERIELLES

COMPONENTI PRINCIPALI

- 2, 3 o più elettropompe identiche tra loro
- Base e porta quadro in lamiera verniciata a polvere
- Collettori di aspirazione e di mandata
- Valvole di intercettazione in aspirazione e mandata di ciascuna elettropompa
- Valvola di ritegno
- Tappi femmina in ghisa, per chiusura collettori
- 1 pressostato per ciascuna pompa installata
- 1 manometro
- Predisposizione all'utilizzo di serbatoio a membrana
- Quadro di comando o inverter
- Viteria

MAIN COMPONENTS

- 2, 3 or more identical electric pumps
- Base and panel holder in powder coated metal sheet
- Suction and delivery manifolds
- Suction and delivery shut-off valves for each electric pump
- check valve
- Female cast iron caps, for closing collectors
- 1 pressure switch for each pump installed
- 1 pressure gauge
- Predisposition for the use of a membrane tank
- Control panel or inverter
- Screws

COMPOSANTS PRINCIPAUX

- 2, 3 ou plus pompes électriques identiques
- Base et support du panneau en tôle enduite de poudre
- Collecteurs d'aspiration et de refoulement
- Clapet d'arrêt d'aspiration et de refoulement pour chaque pompe électrique
- Clapet anti-retour de livraison
- Capuchons femelles en fonte, pour fermer les collecteurs
- 1 pressostat pour chaque pompe installée
- 1 manomètre
- Predisposition à l'utilisation d'un réservoir à membrane
- Panneau de commande ou onduleur
- Visserie

COMPONENTI COMPONENTS	VERSIONE / VERSION		
	Standard	Aisi 304	AISI 316
Elettropompe Electric pump Pompes	Vedi catalogo generale See general catalogue Voire catalogue general	AISI 304	Aisi 316
Collettori Manifolds Collecteurs	Ferro zincato Zincated steel Acier zingué	AISI 304	Aisi 316
Pressostati Pressostats	Ottone nichelato nickel-plated brass laiton nickelé	Ottone nichelato	Aisi 316
Manometro Pressure gauge Manometre	Ottone Brass laiton	Ottone	-
Valvole di ritegno Check valve Clapet non retour	Ottone Brass laiton	Ottone	Aisi 316
Valvole di intercettazione shut-off valves Clapet d'arret	Ottone nichelato nickel-plated brass laiton nickelé	Ottone nichelato	Aisi 316
Controflange pompa (se previste) Counter-flanges (if foreseen) contre-bridés (si prévu)	Ferro zincato Zincated steel acier zingué	Ferro zincato	Aisi 316
Altri componenti Other components Autres composants	Ottone nichelato nickel-plated brass laiton nickelé	Ottone nichelato nickel-plated brass laiton nickelé	Aisi 316

2 GP(E) CB

MOD.	Q = m ³ /h	0	1,8	3,6	4,8	7,2	9,6	12	14,4	16,8	19,2	21,6
	Q = l/min	0	30	60	80	120	160	200	240	280	320	360
2 GP(E) CB/100	H = mt	41	40	36	32	24						
2 GP(E) CB/150		51,5	50	48	47	42	36					
2 GP(E) CB/200		65	64	62	61	57	52	48				
2 GP(E) CB/300		67	66	65	63	61	56	50	45			
2 GP(E) CB/400				72,5	71	67,5	64,5	61	56	49,5	43	
2 GP(E) CB/550				83	82	78	74	70	66	60	52	40
2 GP(E) CB/750				93	91	87	84	80	75	70	59	42

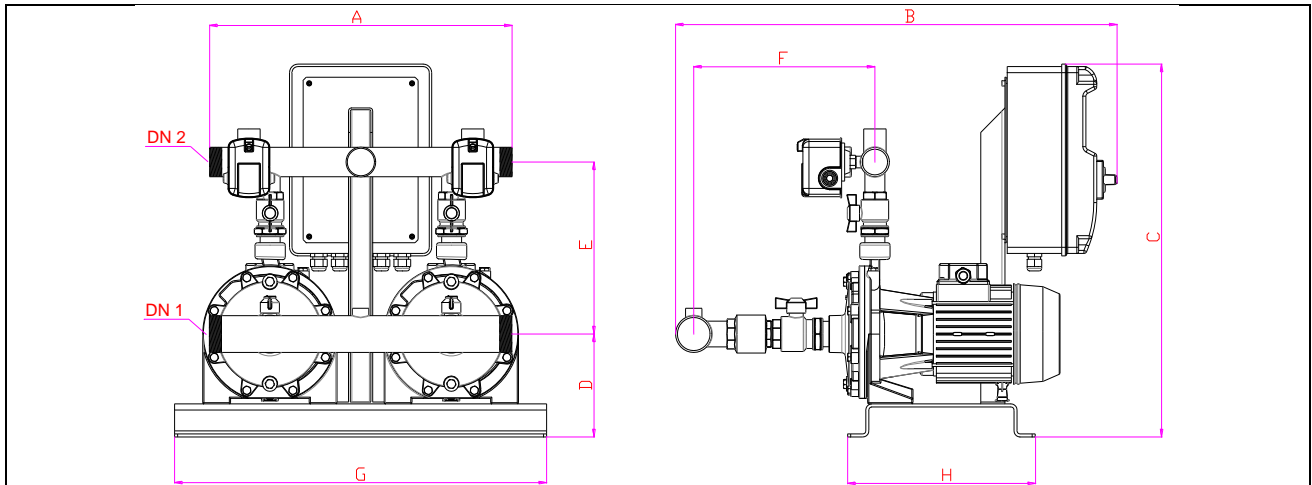
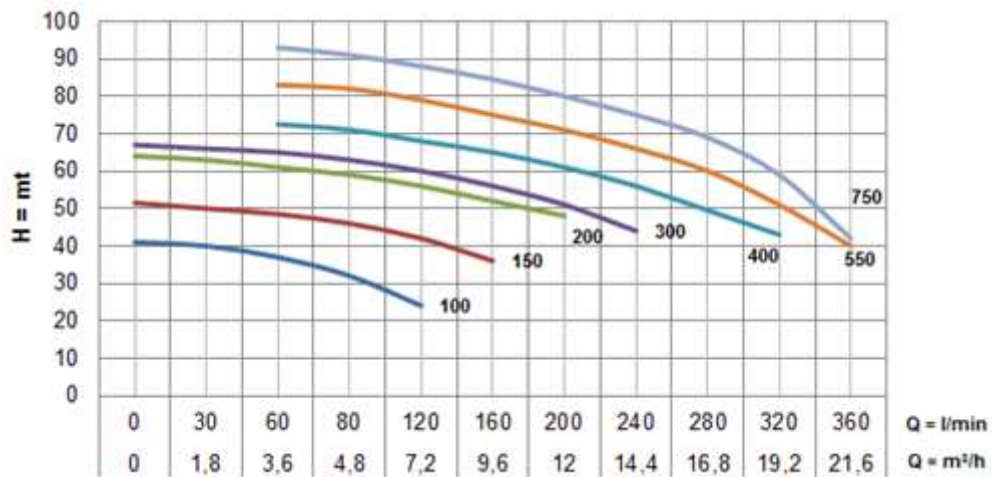

MOD.	Hp	kW	DN 1	DN 2	mm							
					A	B	C	D	E	F	G	H
2 GP(E) CB/100	1,00+1,00	0,75+0,75	G 2	G 1 ½	500	718	609	156	263	290	615	310
2 GP(E) CB/150	1,50+1,50	1,1+1,1	G 2	G 1 ½	500	730	609	168	281	300	615	310
2 GP(E) CB/200	2,00+2,00	1,5+1,5	G 2	G 1 ½	500	730	609	168	281	300	615	310
2 GP(E) CB/300	3,00+3,00	2,2+2,2	G 2	G 1 ½	500	730	609	168	281	300	615	310
2 GP(E) CB/400	4,00+4,00	3,0+3,0	G 2 ½	G 1 ½	500	894	609	186,5	238	397	615	310
2 GP(E) CB/550	5,50+5,50	4,0+4,0	G 2 ½	G 1 ½	500	894	609	186,5	238	397	615	310
2 GP(E) CB/750	7,50+7,50	5,5+5,5	G 2 ½	G 1 ½	500	894	609	186,5	238	397	615	310

2 GP(E) CB..A

MOD.	Q = m ³ /h	0	3,0	6,0	9,0	12,0	18,0	24,0	30,0
	Q = l/min	0	50	100	150	200	300	400	500
2 GP(E) CB/150A	H = mt	39,5	39	38	36,5	33	21		
2 GP(E) CB/200A		43	42,5	41,5	40,5	39	32		
2 GP(E) CB/300A		45,5	45,2	45	44	42,5	38	30	19

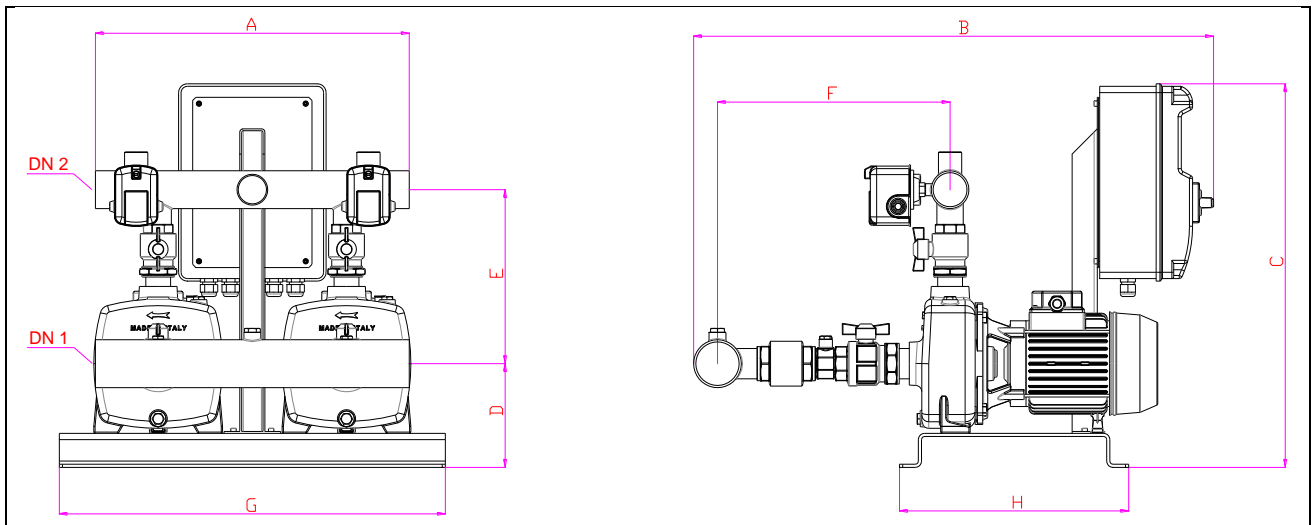
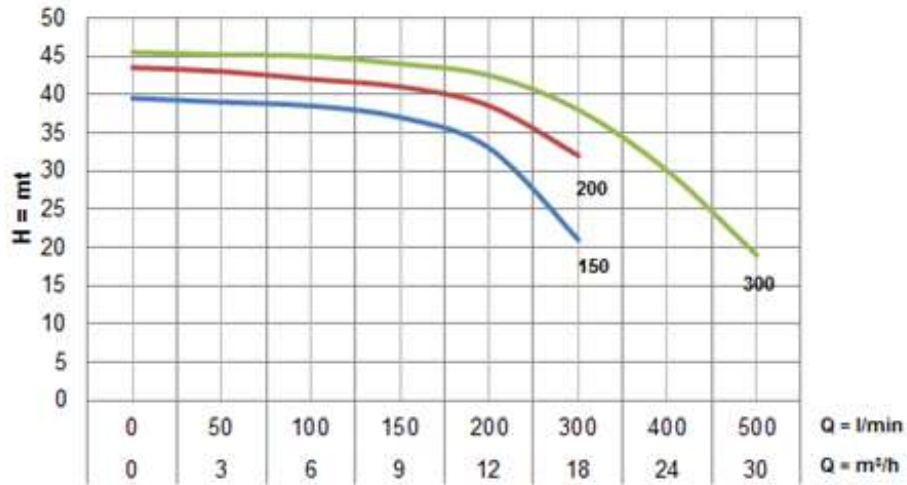

Mod.	Hp	kW	DN 1	DN 2	mm							
					A	B	C	D	E	F	G	H
2 GP(E) CB/150A	1,50+1,50	1,1+1,1	G 2 ½	G 1 ½	500	828	609	165	276	371	615	310
2 GP(E) CB/200A	2,00+2,00	1,5+1,5	G 2 ½	G 1 ½	500	828	609	165	276	371	615	310
2 GP(E) CB/300A	3,00+3,00	2,2+2,2	G 2 ½	G 1 ½	500	828	609	165	276	371	615	310

2 GP(E)CF

MOD.	Q = m ³ /h	0	2,4	4,8	7,2	9,6	12,0	14,4	16,8
	Q = l/min	0	40	80	120	160	200	240	280
2 GP(E) CF/50	H = mt	21	19	17,5	15	12,5			
2 GP(E) CF/80		26,5	25,5	23	19	15,5			
2 GP(E) CF/100		33	31	30	28	25	21		
2 GP(E) CF/150		40	38,5	36,5	35	33,5	31,5	30	
2 GP(E) CF/200		47,5	45,5	44	43	41	39	36,5	33
2 GP(E) CF/300		52,5	51	49,5	48	46	44	41,5	38

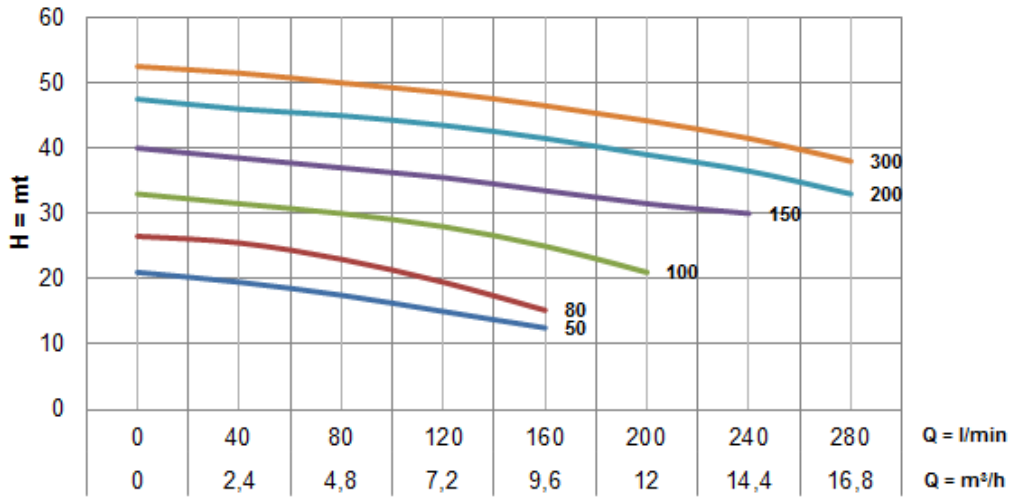

Mod.	Hp	kW	DN 1	DN 2	mm							
					A	B	C	D	E	F	G	H
2 GP(E) CF/50	0,50+0,50	0,37+0,37	G 1 ½	G 1 ½	500	684	609	139	261	263	615	310
2 GP(E) CF/80	0,75+0,75	0,55+0,55	G 1 ½	G 1 ½	500	724	609	155	273	271	615	310
2 GP(E) CF/100	1,00+1,00	0,75+0,75	G 1 ½	G 1 ½	500	724	609	155	273	271	615	310
2 GP(E) CF/150	1,50+1,50	1,1+1,1	G 2	G 1 ½	500	724	609	159	291	277	615	310
2 GP(E) CF/200	2,00+2,00	1,5+1,5	G 2	G 1 ½	500	724	609	159	291	277	615	310
2 GP(E) CF/300	3,00+3,00	2,2+2,2	G 2	G 1 ½	500	724	609	159	291	277	615	310

2 GP(E) CBX

MOD.	Q = m ³ /h	2,4	4,8	7,2	9,6	12,0	14,4	18	21,6	25,2
	Q = l/min	40	80	120	160	200	240	300	360	420
2 GP(E) CBX/100	H = mt	38,5	35	31,5	27					
2 GP(E) CBX/120		44,5	40,3	35,2	29					
2 GP(E) CBX/150		52,5	48	42,8	36,5					
2 GP(E) CBX/200		60	55,6	50	44					
2 GP(E) CBX/150A			42	41,5	39,5	37,5	35	30		
2 GP(E) CBX/200A			51,5	49,5	47	45	42	36,5		
2 GP(E) CBX/300			59	57	54,6	52	49	44		
2 GP(E) CBX/400			68,5	66,5	64	61	57,5	52		
2 GP(E) CBX/300A				52	51	49,5	48	45,5	42,6	39,5
2 GP(E) CBX/400A				62,5	61	59,5	58	55	52,2	49
2 GP(E) CBX/500				71,5	70	68,5	67	64	61,3	57,5

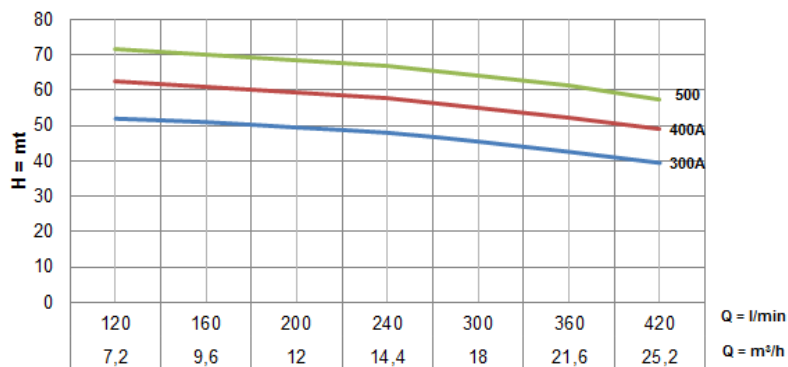
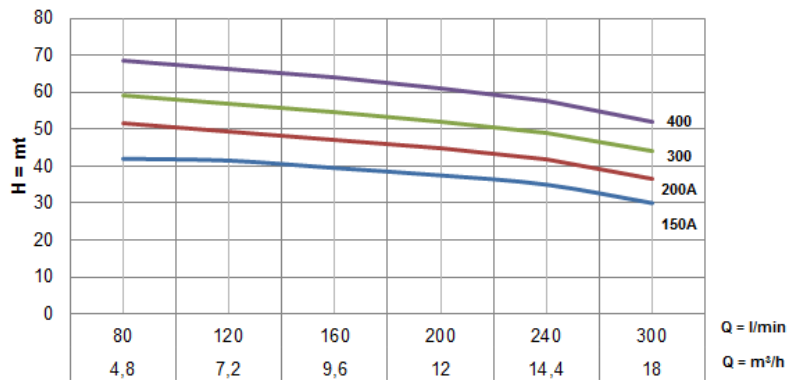
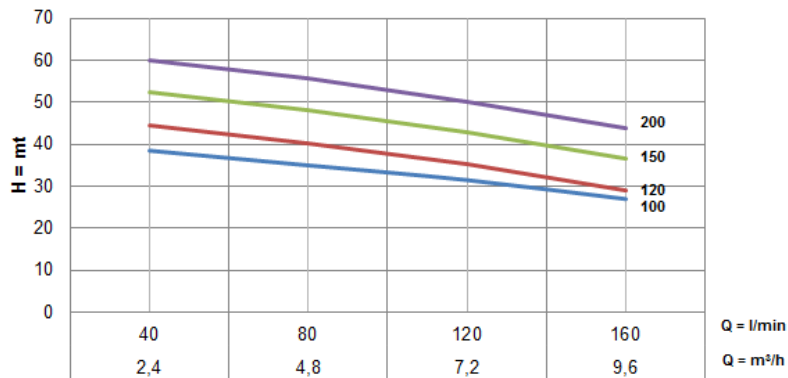

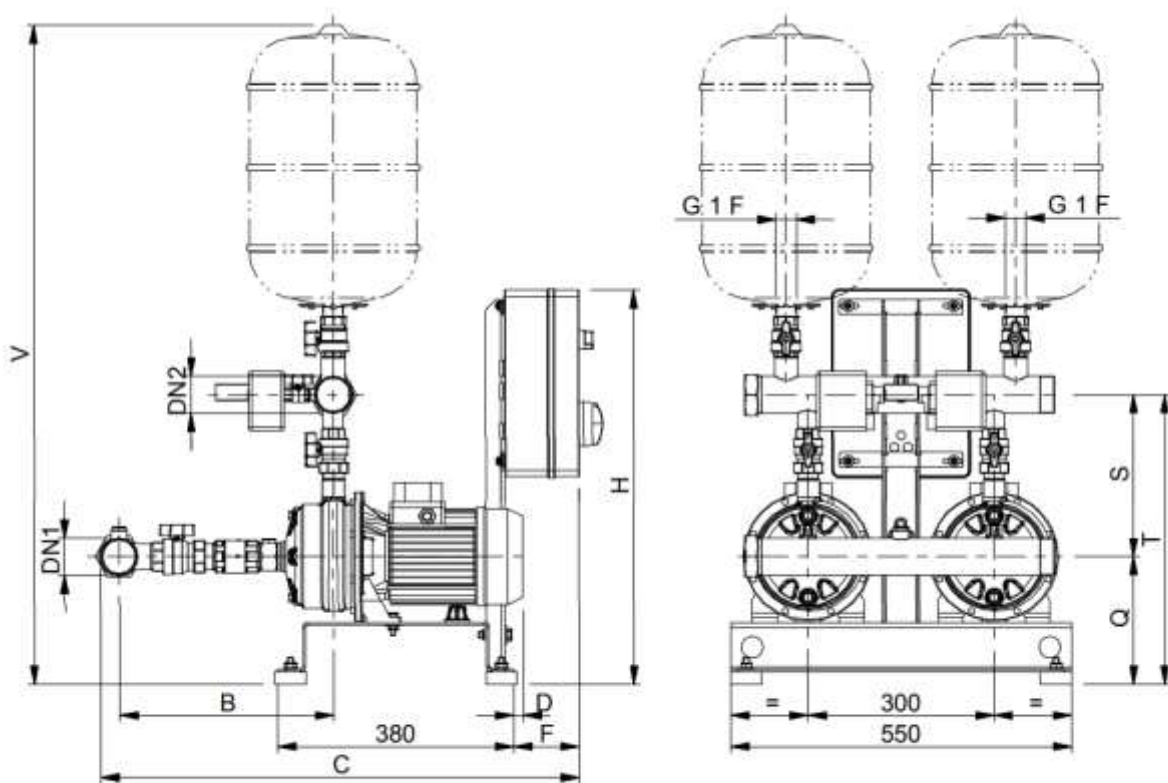

MOD.	Hp	kW	Mm													KG	
			A	B	B1	C	C1	D	DNA	DNM	HQ		M	R	Q	±	3
											(2)	(1)					
2 GP(E) CBX/100	1+1	0,75+0,75	525	165	360	420	385	790	50	40	585	600	410	1130	-	53	53
2 GP(E) CBX/120	1,2+1,2	0,9+0,9	525	165	360	420	385	790	50	40	585	600	410	1130	-	53	54
2 GP(E) CBX/150	1,5+1,5	1,1+1,1	550	180	370	420	385	790	50	40	610	625	410	1155	-	63	62
2 GP(E) CBX/200	2+2	1,5+1,5	550	180	370	420	385	790	50	40	610	625	410	1155	-	64	66
2 GP(E) CBX/150A	1,5+1,5	1,1+1,1	535	165	370	485	445	855	65	50	595	610	475	1145	-	64	63
2 GP(E) CBX/200A	2+2	1,5+1,5	535	165	370	485	445	855	65	50	595	610	475	1145	-	62	66
2 GP(E) CBX/300	3+3	2,2+2,2	555	180	375	485	445	870	65	50	645	660	490	1165	-	-	78
2 GP(E) CBX/400	4+4	3+3	555	180	375	485	445	870	65	50	645	660	490	1165	-	-	85
2 GP(E) CBX/300A	3+3	2,2+2,2	585	165	420	465	425	850	65	65	650	665	470	1205	-	-	83
2 GP(E) CBX/400A	4+4	3+3	610	180	430	465	425	850	65	65	675	690	470	1230	-	-	86
2 GP(E) CBX/500	5+5	4+4	610	180	430	465	425	860	65	65	675	690	470	1230	10	-	104

2 GP(E) MCH

MOD.	Q = m ³ /h	0	1,2	2,4	3,6	4,8	6,0	7,2	8,4	9,6	12,0	14,4	16,8	19,2
	Q = l/min	0	20	40	60	80	100	120	140	160	200	240	280	320
2 GP(E) MCH/80	H = mt	48	46	44,5	42	39	35	31	26	21	16			
2 GP(E)MCH/100		61	59	57	54	50	44	39	32	27	20			
2 GP(E)MCH/150		49	48	47	46	44	43	41,5	40	38,5	34	28,5	22	14
2 GP(E)MCH/200		63	62	60	58	56,5	55	53	51	49	43	37	29	18
2 GP(E)MCH/300		74	72	70	68,5	66	64	62,5	60	58	52	43	34	22

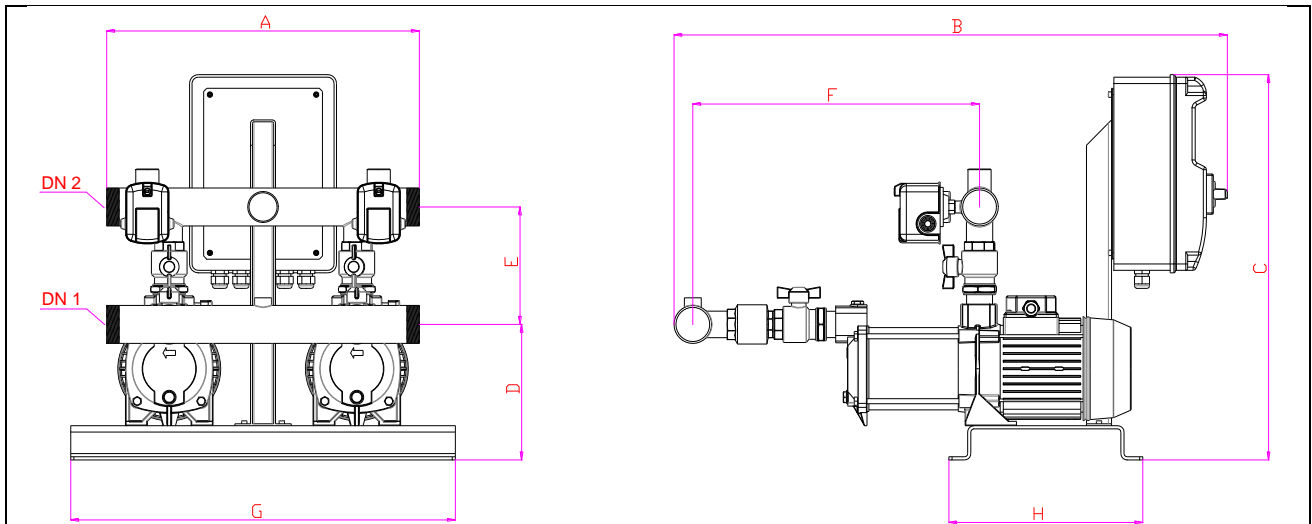
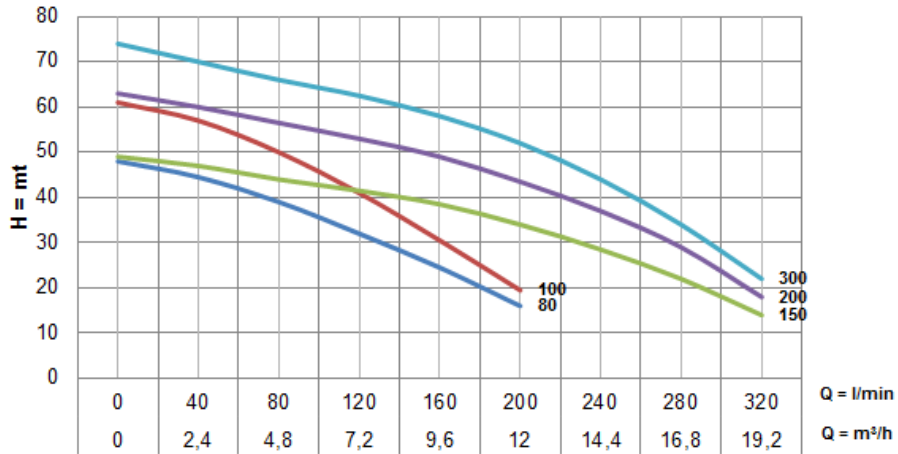

Mod.	Hp	kW	DN 1	DN 2	mm							
					A	B	C	D	E	F	G	H
2 GP(E) MCH/80	0,75+0,75	0,55+0,55	G 1 ½	G 1 ½	500	804	609	169	187	394	615	310
2 GP(E)MCH/100	1,00+1,00	0,75+0,75	G 1 ½	G 1 ½	500	828	609	169	187	418	615	310
2 GP(E)MCH/150	1,50+1,50	1,1+1,1	G 2	G 2	500	885	609	214	186	459	615	310
2 GP(E)MCH/200	2,00+2,00	1,5+1,5	G 2	G 2	500	913	609	214	186	487	615	310
2 GP(E)MCH/300	3,00+3,00	2,2+2,2	G 2	G 2	500	941	609	214	186	515	615	310

2 GP(E) MCV

MOD.	Q = m ³ /h	0	1,2	2,4	3,6	4,8	6,0	7,2	8,4	9,6	12,0	14,4	16,8	19,2
	Q = l/min	0	20	40	60	80	100	120	140	160	200	240	280	320
2 GP(E) MCV 150	H = mt	49	48	47	46	44	43	41,5	40	38,5	34	28,5	22	14
2 GP(E) MCV 200		63	62	60	58	56,5	55	53	51	49	43	37	29	18
2GP(E) MCV 300		74	72	70	68,5	66	64	62,5	60	58	52	43	34	22

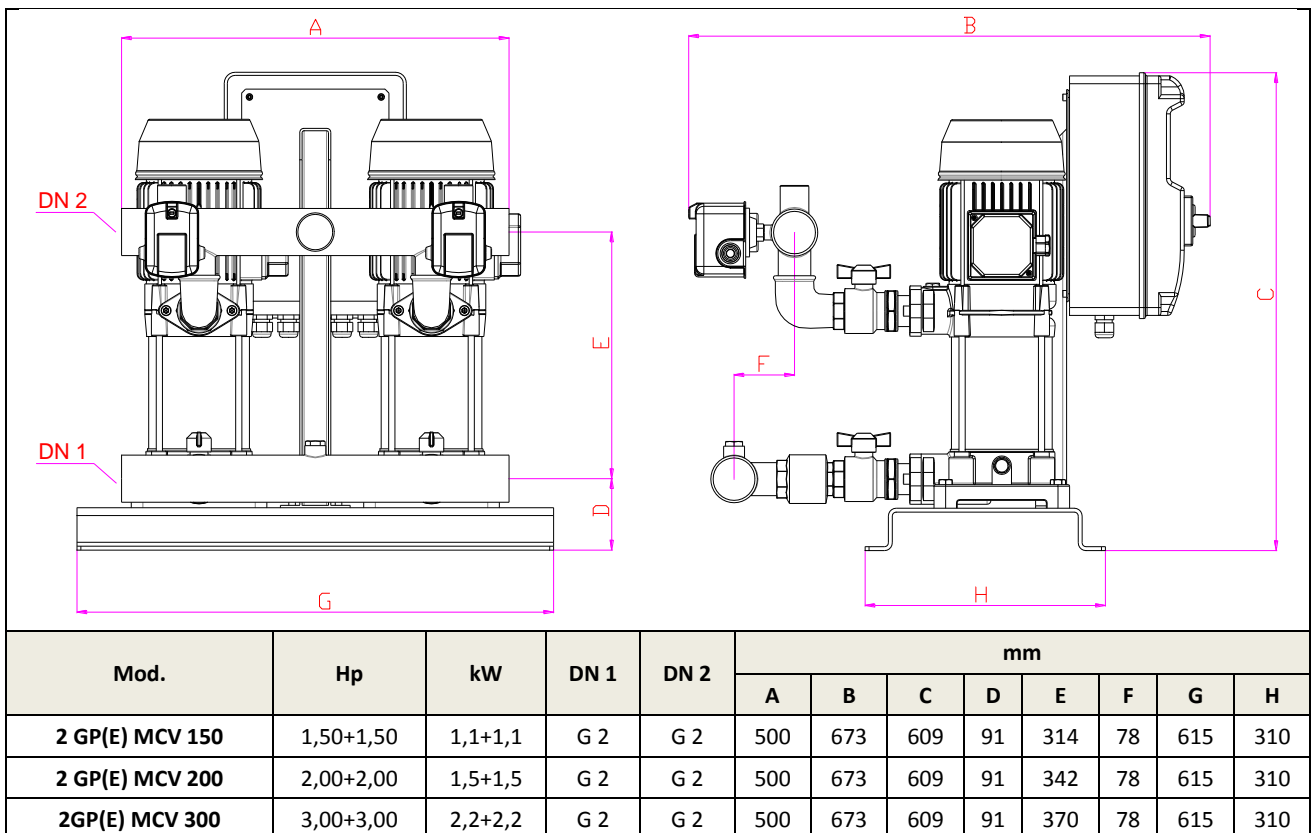
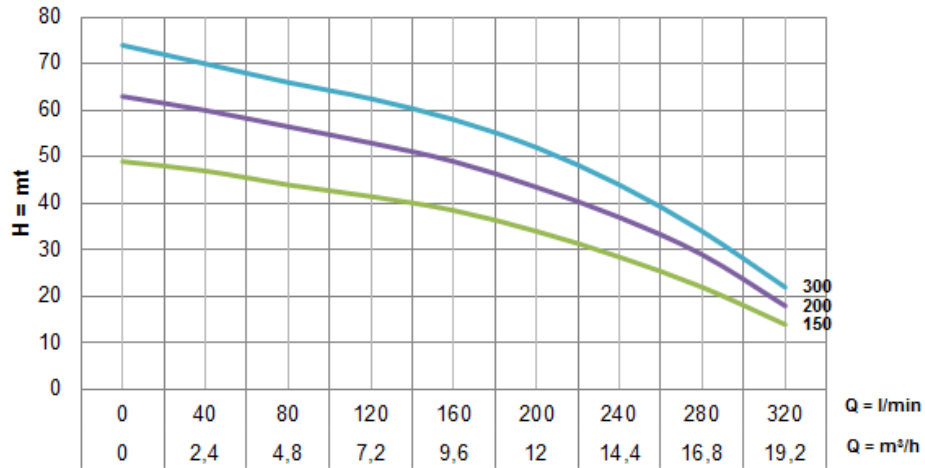

2 GP(E) EHX

MOD.	Q = m ³ /h	0	3,0	4,0	5,0	6,0	7,0	8,0	9,0	10,0	11,0	12,0	14,0	16,0	18,0	20,0	22,0	28,0
	Q = l/min	0	50	67	83	100	117	133	150	167	183	200	233	267	300	333	367	467
2 GP(E) EH 3/3	H = mt	33,5	30,5	29	26,5	24	21	17,5	14									
2 GP(E) EH 3/4		44,5	40	37,5	34,5	31	27	23	18									
2 GP(E) EH 3/5		55	49	46	42	37	32,5	27	21									
2 GP(E) EH 3/6		67,5	61	57	53	47	41,5	35	28									
2 GP(E) EH 3/7		78	70,5	66	60,5	54	47,5	40	32									
2 GP(E) EH 3/8		90	82	77	71	64,0	56	47	38									
2 GP(E) EH 3/9		101	91,5	85,5	79	70,5	61,5	52	41									
2 GP(E) EH 5/3		34,5		31,5	31	29,5	28,5	27,5	26	25	23	21	16					
2 GP(E) EH 5/4		46,5		43	42	41	39,5	38	36	34	32	29	23					
2 GP(E) EH 5/5		58		53	51,5	50	48,5	46,5	44	41,5	38,5	35,5	17,5					
2 GP(E) EH 5/6		70		64,5	63	61	59	56,5	54	51	47,5	43,5	34					
2 GP(E) EH 5/7		81,5		74,5	72,5	70	68	65	61,5	58	54	49,5	38,5					
2 GP(E) EH 5/8		92,5		84	82	79	76,5	73	69	65	60	54,5	42					
2 GP(E) EH 5/9		104		95,5	93	90,5	87,5	83,5	79,5	75	70	64	50					
2 GP(E) EH 9/3		35,5				33	32,5	32	31,5	31	30,5	30	28,5	27,5	26	24	21	11
2 GP(E) EH 9/4		48				45	44,5	43,5	43	42	41,5	41	39,5	38	36	33	39,5	16
2 GP(E) EH 9/5		59,5				55,5	55	54	53	52	51	50	48,5	46,5	44	40,5	36	18,5
2 GP(E) EH 9/6		71				66	65	64	62,5	61,5	60	59	57	54,5	51	47	41,5	21
2 GP(E) EH 9/7		84				79,5	78,5	77,5	76	74,5	73,5	72	70	67	64	59,5	53,5	29,5
2 GP(E) EH 9/8		96				90,5	89,5	88	86	84,5	83	82	79,5	76	72,5	67	60	32,5

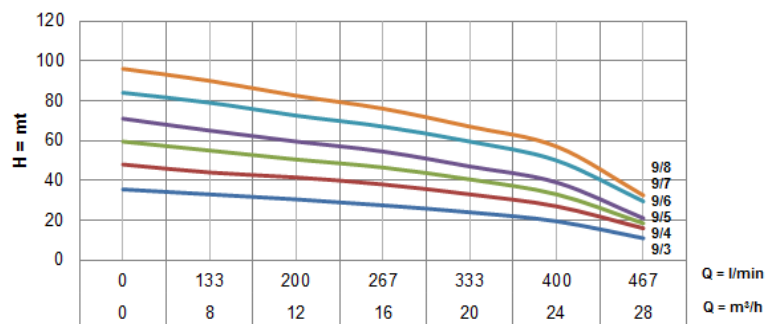
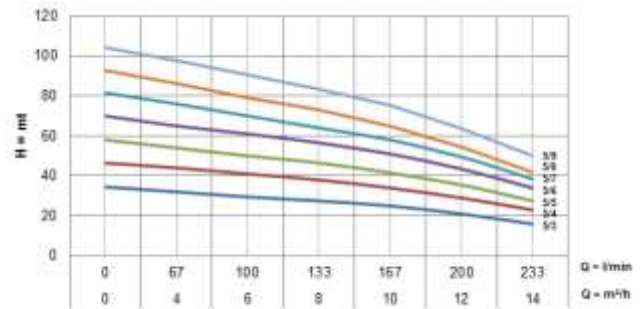
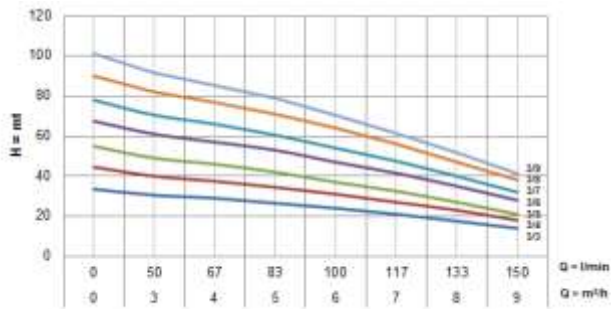

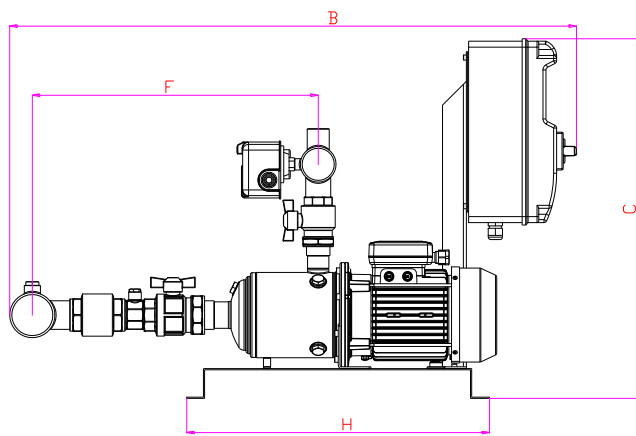
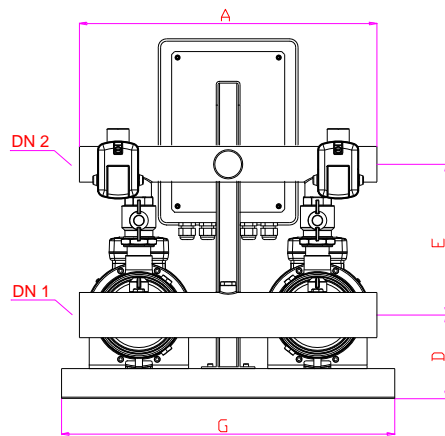

Mod.	1~ 230V 50Hz		3~ 230-400V 50Hz		DN 1	DN 2	mm							
	Hp	kW	Hp	kW			A	B	C	D	E	F	G	H
2 GP(E) EH 3/3	0,60+0,60	0,45+0,45	1,0+1,0	0,75+0,75	G 2	G 1 ½	500	642	559	140	239	382	560	509
2 GP(E) EH 3/4	0,75+0,75	0,55+0,55	1,0+1,0	0,75+0,75	G 2	G 1 ½	500	666	559	140	239	406	560	509
2 GP(E) EH 3/5	1,0+1,0	0,75+0,75	1,0+1,0	0,75+0,75	G 2	G 1 ½	500	690	559	140	239	430	560	509
2 GP(E) EH 3/6	1,2+1,2	0,90+0,90	1,5+1,5	1,1+1,1	G 2	G 1 ½	500	714	559	140	239	454	560	509
2 GP(E) EH 3/7	1,5+1,5	1,1+1,1	1,5+1,5	1,1+1,1	G 2	G 1 ½	500	738	559	140	239	478	560	509
2 GP(E) EH 3/8	1,8+1,8	1,3+1,3	2	1,5+1,5	G 2	G 1 ½	500	799	559	140	239	502	560	509
2 GP(E) EH 3/9	2,0+2,0	1,5+1,5	2	1,5+1,5	G 2	G 1 ½	500	823	559	140	239	526	560	509
2 GP(E) EH 5/3	0,75+0,75	0,55+0,55	1,0+1,0	0,75+0,75	G 2	G 1 ½	500	642	559	140	239	382	560	509
2 GP(E) EH 5/4	1,2+1,2	0,90+0,90	1,5+1,5	1,1+1,1	G 2	G 1 ½	500	666	559	140	239	406	560	509
2 GP(E) EH 5/5	1,5+1,5	1,1+1,1	1,5+1,5	1,1+1,1	G 2	G 1 ½	500	690	559	140	239	430	560	509
2 GP(E) EH 5/6	1,8+1,8	1,3+1,3	2,0+2,0	1,5+1,5	G 2	G 1 ½	500	751	559	140	239	454	560	509
2 GP(E) EH 5/7	2+2	1,5+1,5	2,0+2,0	1,5+1,5	G 2	G 1 ½	500	775	559	140	239	478	560	509
2 GP(E) EH 5/8	2,5+2,5	1,85+1,85	3,0+3,0	2,2+2,2	G 2	G 1 ½	500	846	559	140	239	502	560	509
2 GP(E) EH 5/9	3+3	2,2+2,2	3,0+3,0	2,2+2,2	G 2	G 1 ½	500	870	559	140	239	526	560	509
2 GP(E) EH 9/3	1,5+1,5	1,1+1,1	1,5+1,5	1,1+1,1	G 2 ½	G 2	500	695	559	140	340	431	560	509
2 GP(E) EH 9/4	2,0+2,0	1,5+1,5	2,0+2,0	1,5+1,5	G 2 ½	G 2	500	762	559	140	340	461	560	509
2 GP(E) EH 9/5	3,0+3,0	2,2+2,2	3,0+3,0	2,2+2,2	G 2 ½	G 2	500	839	559	140	340	491	560	509
2 GP(E) EH 9/6	3,0+3,0	2,2+2,2	3,0+3,0	2,2+2,2	G 2 ½	G 2	500	869	559	140	340	521	560	509
2 GP(E) EH 9/7	3,0+3,0	2,2+2,2	4,0+4,0	3,0+3,0	G 2 ½	G 2	500	934	559	140	340	551	560	509
2 GP(E) EH 9/8	-	-	4,0+4,0	3,0+3,0	G 2 ½	G 2	500	964	559	140	340	581	560	509

GP ... EVX

2 GPE EVX



2 GPV EVX



3GPE EVX*



3GPV EVX*



**Modelli a richiesta / Models on request / Models sur demande*

2 GP(E) EVX 3

MOD.	Q = m ³ /h	0	1	2	3	4	5	6	7	8	9
	Q = l/min	0	16,67	33,33	50	66,67	83,33	100	116,67	133,33	150
2 GP(E) EVX 3/7	H = mt	52.5		50.5	48.5	46	43	38.5	33	26.5	19
2 GP(E) EVX 3/9		64		64	61.5	58	53.5	48	41	32.5	22.5
2 GP(E) EVX 3/13		96.5		93	89	84.5	78	70	60	47.5	33.5
2 GP(E) EVX 3/14		105.5		102	98.5	93.5	86.5	78	67.5	54.5	39.5
2 GP(E) EVX 3/17		127		122.5	118	111.5	103.5	93	80	64	45.5
2 GP(E) EVX 3/18		136.5		132.5	128	121.5	113.5	102.5	89	72.5	53
2 GP(E) EVX 3/21		158.5		153.5	148	140.5	130.5	118	102	83	60

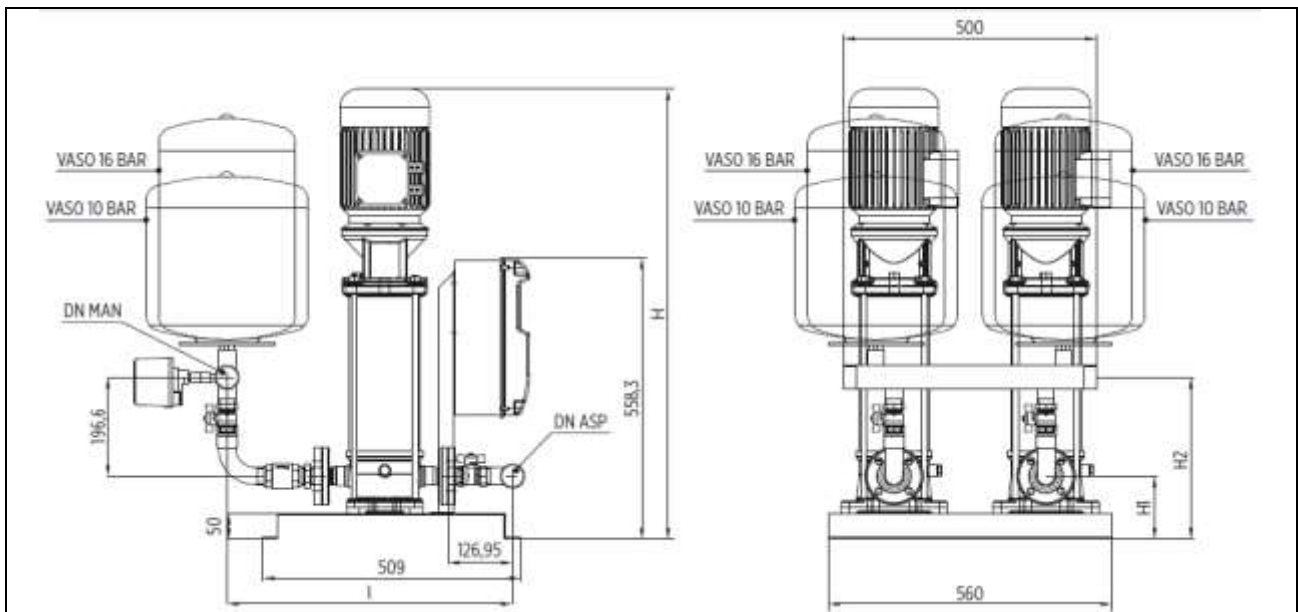
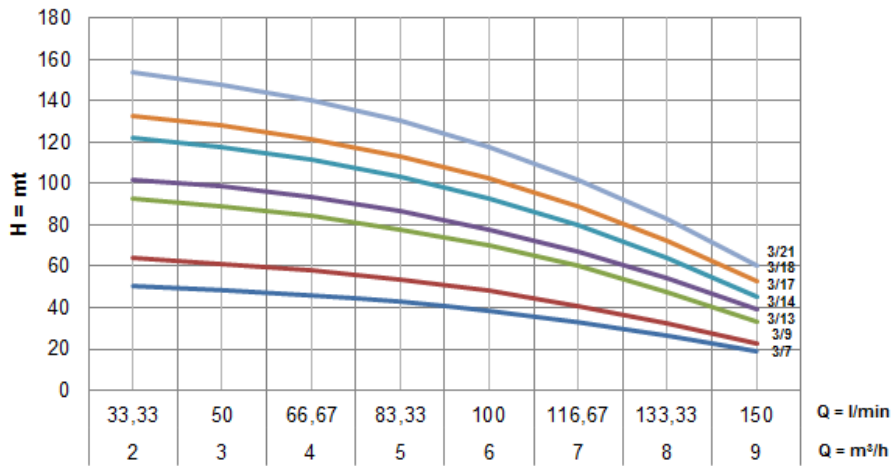

MOD	KW	HP					DNA	DNM	KG
			H	H1	H2	I			
2 GP(E) EVX 3/7	0.75+0.75	1+1	708	125	321,6	563,12	G2"	G2"	90
2 GP(E) EVX 3/9	0.75+0.75	1+1	753	125	321,6	563,12			93
2 GP(E) EVX 3/13	1.1+1.1	1.5+1.5	843	125	321,6	563,12			108
2 GP(E) EVX 3/14	1.5+1.5	2+2	910	125	321,6	563,12			109
2 GP(E) EVX 3/17	1.5+1.5	2+2	978	125	321,6	563,12			112
2 GP(E) EVX 3/18	2.2+2.2	3+3	1000	125	321,6	563,12			117
2 GP(E) EVX 3/21	2.2+2.2	3+3	1068	125	321,6	563,12			119

2 GP(E) EVX 6

MOD.	Q = m ³ /h	0	2	4	6	8	10	12	14
	Q = l/min	0,00	33,33	66,66	100,00	133,33	166,66	199,99	233,32
2 GP(E) EVX 6/3	H = mt	22,5	22	21	19,5	18	16	14	11
2 GP(E) EVX 6/4		29,5	29	28	26	24	21,5	18,5	14,5
2 GP(E) EVX 6/6		44,5	43,5	42	39,5	36	32,5	28	22
2 GP(E) EVX 6/9		67	65,5	63,5	59	54	48,5	42,5	33,5
2 GP(E) EVX 6/13		97	95	92	86	78,5	70,5	61,5	48,5
2 GP(E) EVX 6/14		105,5	104,5	101,5	95,5	88	79,5	70	56
2 GP(E) EVX 6/19		142	139,5	135,5	126,5	115,5	104	91	72

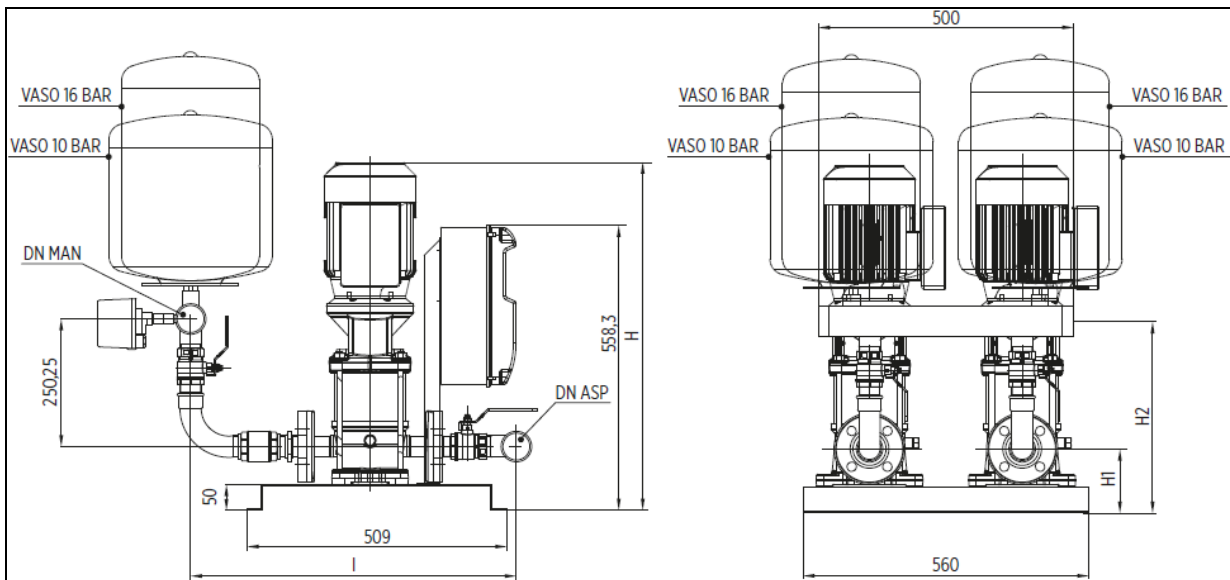
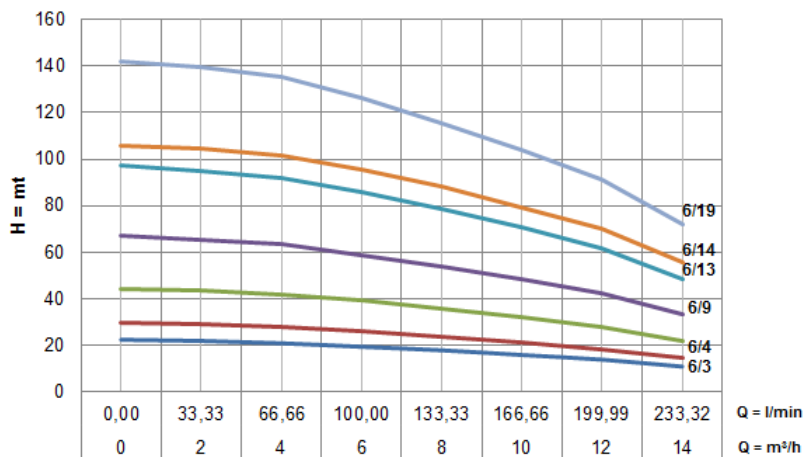

MOD	KW	HP	H				DNA	DNM	KG
			H	H1	H2	I			
2 GP(E) EVX 6/3	0.37+0.37	0.5+0.5	486	125	375,25	638,15	G2"	G2"	102
2 GP(E) EVX 6/4	0.55+0.55	0.75+0.75	556	125	375,25	638,15			105
2 GP(E) EVX 6/6	0.75+0.75	1+1	706	125	375,25	638,15			110
2 GP(E) EVX 6/9	1.1+1.1	1.5+1.5	7847	125	375,25	638,15			120
2 GP(E) EVX 6/13	1.5+1.5	2+2	933	125	375,25	638,15			135
2 GP(E) EVX 6/14	2.2+2.2	3+3	959	125	375,25	638,15			136
2 GP(E) EVX 6/19	2.2+2.2	3+3	1089	125	375,25	638,15			144

2 GP(E) EVX 10

MOD.	Q = m ³ /h	4	6	8	10	12	14
	Q = l/min	66,66	100,00	133,33	166,66	200,00	233,32
2 GP(E) EVX 10/3	H = mt	29,5	28	26	23,5	19	13,5
2 GP(E) EVX 10/5		48,5	46,5	42,5	37	30,5	21,5
2 GP(E) EVX 10/7		68,5	64,5	59	52,5	44	31
2 GP(E) EVX 10/9		89,5	84,5	78	69,5	58	42
2 GP(E) EVX 10/12		120,5	114	105,5	94	80	57,5
2 GP(E) EVX 10/15		150,5	142,5	132	118	100	72

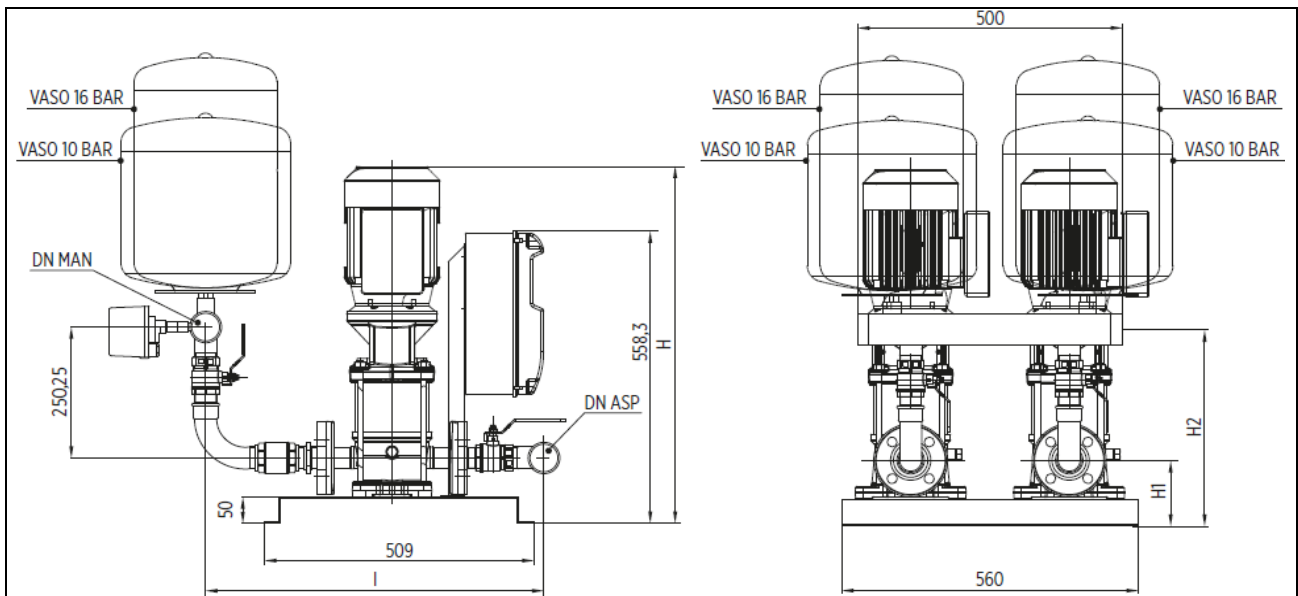
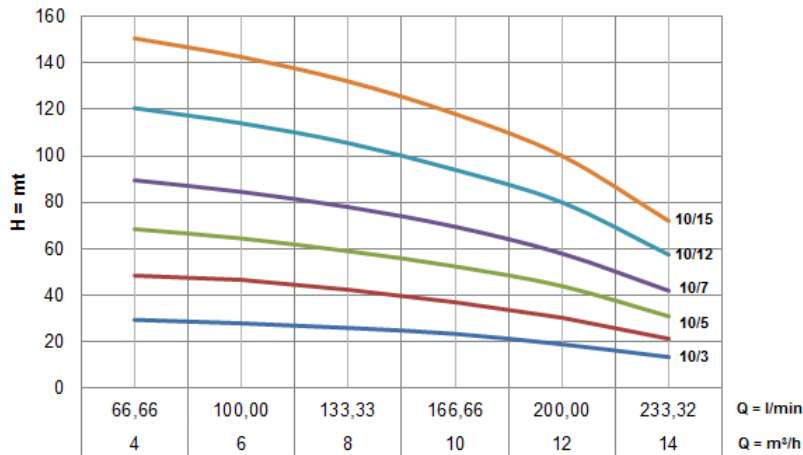

MOD	KW	HP	H				DNA	DNM	KG
			H	H1	H2	I			
2 GP(E) EVX 10/3	1.1+1.1	1.5+1.5	663	140	409	700	G2,5"	G2,5"	102
2 GP(E) EVX 10/5	1.5+1.5	2+2	768	140	409	700			105
2 GP(E) EVX 10/7	2.2+2.2	3+3	828	140	409	700			110
2 GP(E) EVX 10/9	3+3	4+4	937	140	409	700			120
2 GP(E) EVX 10/12	3+3	4+4	997	140	409	700			135
2 GP(E) EVX 10/15	4+4	5.5+5.5	1314	140	409	700			136

2GP(E) EVX 15

MOD.	Q = m ³ /h	0	8	10	12	14	16	18	20	22	24
	Q = l/min	0	133	167	200	233	266	300	333	367	400
2 GP (E) EVX 15/2	H = mt	29	26	25	24	23	22	20	17	14	11
2 GP (E) EVX 15/3		44	39	38	37	35	33	30	26	22	17
2 GP (E) EVX 15/5		73	66	64	61	58	55	50	43	36	29
2 GP (E) EVX 15/7		102	92	89	86	82	78	71	62	53	42
2 GP (E) EVX 15/9		132	119	116	111	106	101	92	81	69	55
2 GP (E) EVX 15/10		148	135	131	127	121	115	106	94	81	65

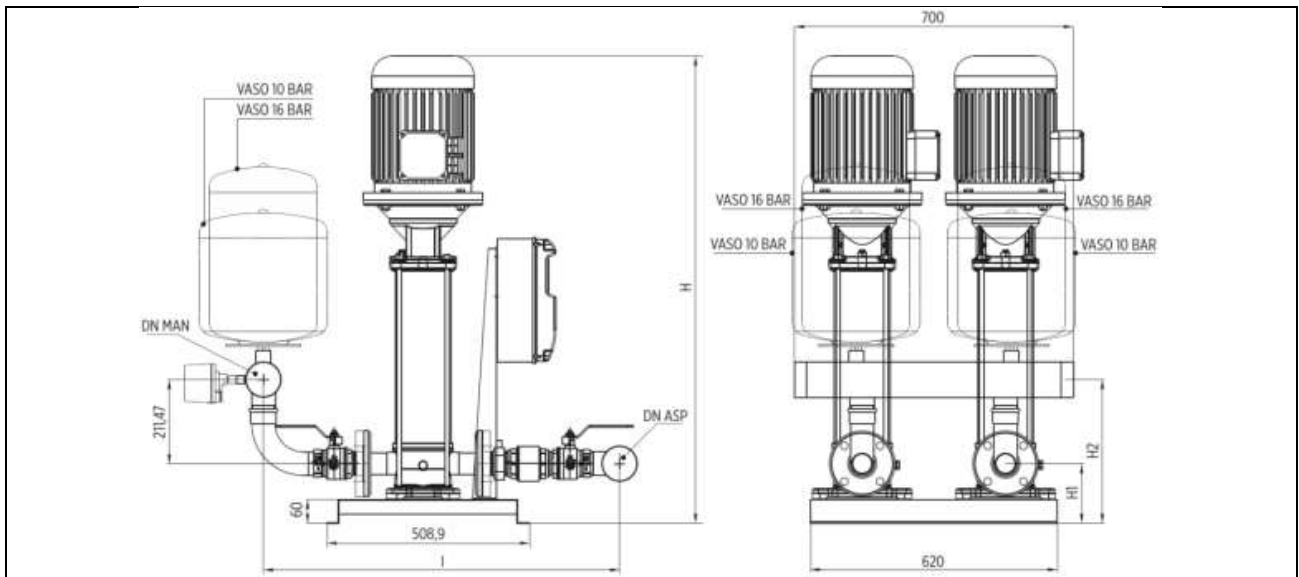
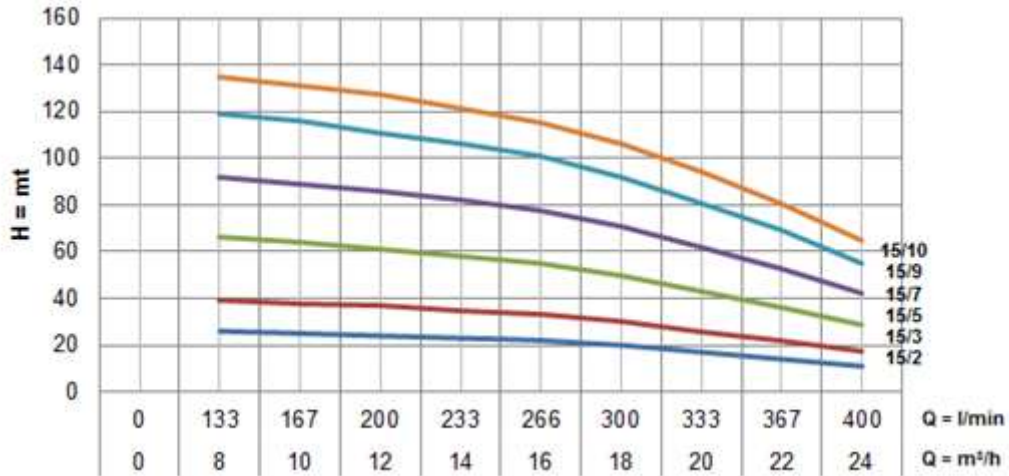

MOD	KW	HP					DNA	DNM	KG
			H	H1	H2	I			
2 GP (E) EVX 15/2	2.2+2.2	3+3	738	150	467	790	G 3"	G 3"	120
2 GP (E) EVX 15/3	3+3	4+4	835	150	467	790			125
2 GP (E) EVX 15/5	4+4	5.5+5.5	931	150	467	790			150
2 GP (E) EVX 15/7	5.5+5.5	7.5+7.5	1188	150	467	790			170
2 GP (E) EVX 15/9	7.5+7.5	10+10	1354	150	467	790			180
2 GP (E) EVX 15/10	11+11	15+15	1497	150	467	790			190

2 GP (E) EVX 20

MOD.	Q = m ³ /h	0	8	10	12	14	16	18	20	22	24	26	28
	Q = l/min	0	133	167	200	233	266	300	333	367	400	433	467
2 GP (E) EVX20/2	H = mt	31		28	27	26	25	24	23	21	18	15	12
2 GP (E) EVX20/3		47		42	41	40	38	37	35	31	28	23	19
2 GP (E) EVX20/5		78		70	69	67	65	62	58	53	47	40	33
2 GP (E) EVX20/7		110		101	98	96	93	90	85	78	69	60	49
2 GP (E) EVX20/10		158		146	142	139	135	132	125	114	102	89	73

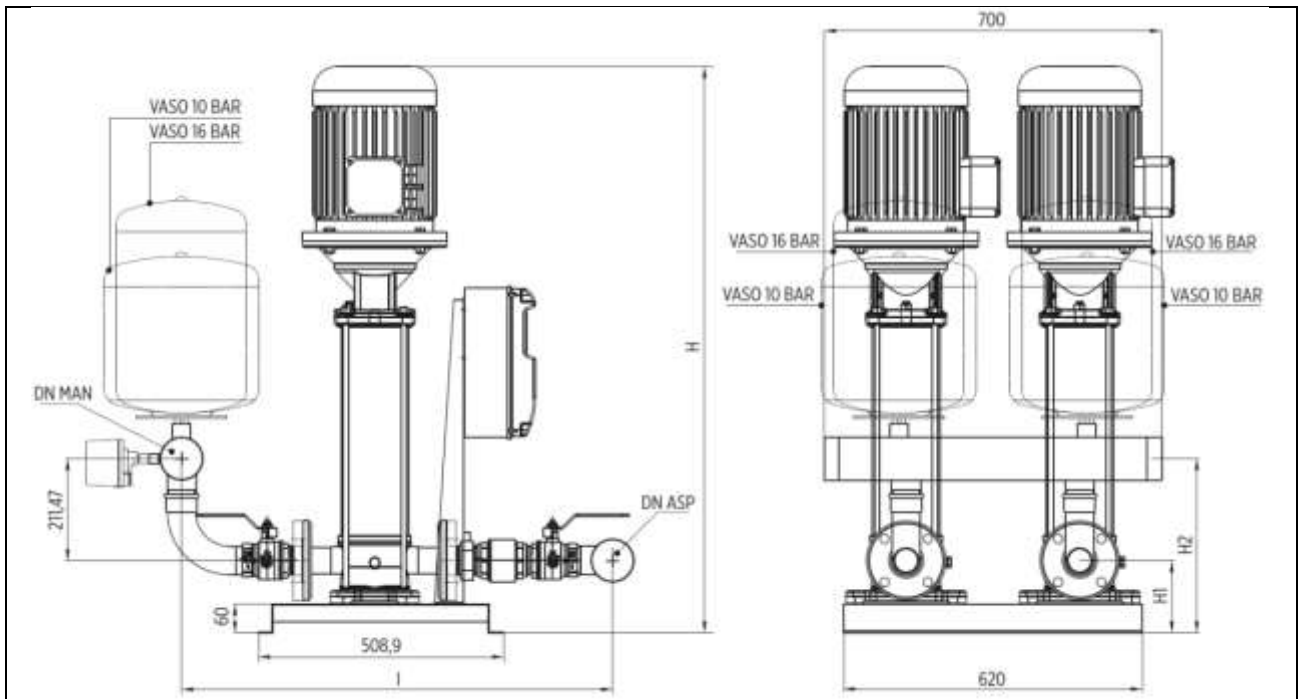
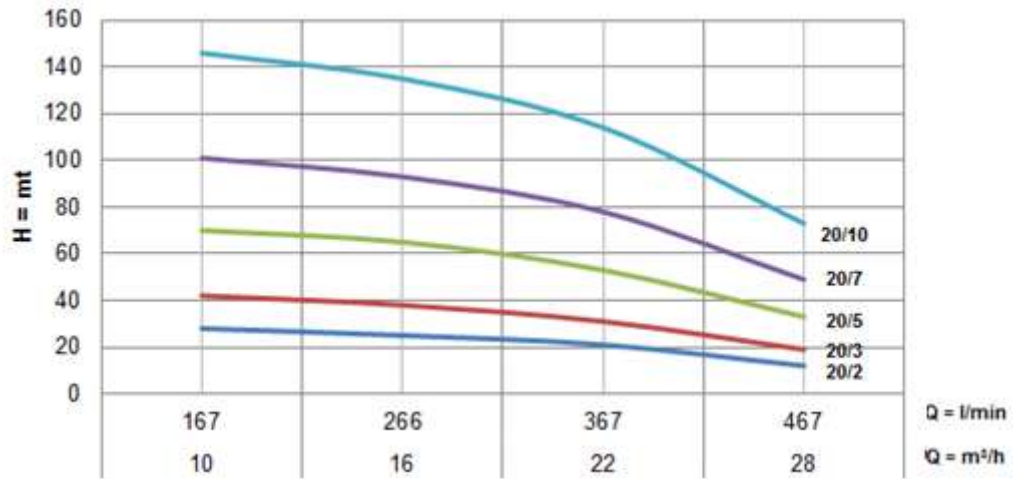

MOD	KW	HP	H				DNA	DNM	KG
			H	H1	H2	I			
2 GP (E) EVX20/2	2.2+2.2	3+3	738	150	467	790	G 3"	G 3"	120
2 GP (E) EVX20/3	4+4	4+4	835	150	467	790			125
2 GP (E) EVX20/5	5.5+5.5	5.5+5.5	1140	150	467	790			150
2 GP (E) EVX20/7	7.5+7.5	7.5+7.5	1258	150	467	790			170
2 GP (E) EVX20/10	11+11	10+10	1497	150	467	790			180

ACCESSORI

ACCESSORIES

ACCESSOIRES

QUADRO DI CONTROLLO ELETTRONICO SERIE SIMPLEX / DUPLEX / TRIPLEX
ELECTRONIC CONTROL BOX SERIES SIMPLEX / DUPLEX / TRIPLEX
TABLEAU DE CONTROLE ELECTRONIQUE SERIE SIMPLEX / DUPLEX / TRIPLEX



- Sezionatore generale con bloccaporta
- Fusibili di protezione
- Pulsanti AUTO-0-MAN (momentaneo)
- Spie LED rete, auto, marcia
- Spie LED allarme livello, sovraccarico motore
- Ingresso galleggiante/pressostato com. motore
- Ingresso galleggiante/pressostato Allarme
- Uscita motore:
- Relè(monofase)/Contattore(trifase)
- Protezione motore da sovraccarico regolabile
- Tempo di intervento protezione 5"
- Uscita allarme ottico/acustico 12V 100mA
- Uscita allarme (contatti puliti NC-C-NA)
- Ingresso klixon motore con spia di intervento
- Predisposizione per condensatore di marcia

- Main switch with door interlock
- Protection fuses
- AUTO-0-MAN buttons (manual temporary)
- LED power on, auto operation, motor operating
- LED level alarm, motor overload
- Operating input multi-contact float/pressure switch
- Alarm input multi-contact float/pressure switch
- Output: Relay(single ph.)/Contactor(three ph.)
- Adjustable motor overload protection
- Time for activation of protection 5"
- Optical/acoustic alarm output
- Alarm output (volt free contact NO-COM-NC)
- Klixon input whit indicator light
- Provision for start-up capacitors

- Sectionneur général avec verrouillage de porte
- Fusibles de protection
- Boutons-poussoirs AUTO-0-MAN (momentané)
- LED présence réseau, auto, moteur en fonction
- LED alarm level, surcharges moteur
- Entrée comande interrupteur à flotteur/pressostat
- Entrée alarme interrupteur à flotteur/pressostat
- Sortie moteur:
- Relais(monoph.)/Contacteur(triph.)
- Protection électronique surcharge moteurs réglable
- Temps d'intervention protection 5"
- Sortie alarme sonore/lumineuse
- Sortie alarme (NO-COM-NC volts sans contact)
- Entrée klixon avec voyant lumineux
- Predispositions pour condensateur de démarrage

SIMPLEX-UP

- Ingresso per 3 sonde unipolari
- Selettore riempimento/svuotamento
- Regolatore sensibilità sonda

SIMPLEX-UP

- Input for 3 single-pole level probes
- Selector for filling/emptying probes
- Internal regulator for probes sensitivity

SIMPLEX-UP

- Entrée pour sondes de niveau unipolaire
- Sélecteur fonction. en remplissage/vidage
- Sélecteur intérieur pour sensibilité des sondes

DUPLEX-UP/TRIPLEX-UP

- Alternanza motori escludibile
- 1 ingresso per comando di arresto minimo livello
- DUPLEX: 2 Relè/Contattori - 2 ingressi galleggiante
- TRIPLEX: 3 Relè/Contattori - 3 ingressi galleggiante

DUPLEX-UP/TRIPLEX-UP

- Alternated start-up excludable
- 1 input for stop command for minimum level
- DUPLEX: 2 Relay/Contactors - 2 inputs for float
- TRIPLEX: 3 Relay/Contactors - 3 inputs for float

DUPLEX-UP/TRIPLEX-UP

- Possibilità d'esclusione des l'échange moteurs
- 1 entrée pour la commande d'arrêt niveau min.
- DUPLEX: 2 Relais/Contacteur - 2 entrées flotteur
- TRIPLEX: 3 Relais/Contacteur - 3 entrées flotteur

PHASE	MODEL	POWER		AMPERE	DIMENSIONS*			WEIGHT*	BOX MATERIAL
		KW	HP		L	W	H	KG	
1X230v	SIMPLEX-UP M/3	0.37 – 2.2	0.5 – 3	2-16	340	240	170	1,9	P
3X400V	SIMPLEX-UP T/10	0.55 – 7.5	0.75 – 10	2-15	340	240	170	2,4	P
	SIMPLEX-UP T/15	7.5 – 11	10 – 15	16-24	340	240	170	2,6	P
	SIMPLEX-UP T/20	7.5 - 15	10 - 20	16-35	340	240	170	2,7	P

*dimensioni per quadri per 1 pompa. I quadri con 2 o 3 pompe hanno dimensioni maggiori / sizes for boxes for 1 pump. Boxes for 2 or 3 pumps have bigger sizes / dimensions pour tableaux pour 1 pompe. Les tableaux pour 2 ou 3 pompes ont dimensions majeurs

QUADRO DI CONTROLLO ELETTROMECCANICO SERIE EDOL

ELECTROMECHANICAL CONTROL BOX SERIES EDOL

TABLEAU DE CONTROLE ELECTROMECHANIQUE SERIE EDOL



SERIE EDOL

- Sezionatore generale con bloccaporta
- Fusibili di protezione
- Trasformatore 230-400/24V per circuiti ausiliari
- 1 ingresso per comando di marcia
- 1 ingresso per comando di arresto minimo livello
- Selettore AUTO-0-MAN (man stabile)
- Spia LED blu presenza rete
- Spia LED verde motore in funzione
- Spia LED rossa allarme motore in protezione
- Contattore di linea in AC3
- Relé termico di sovraccarico ripristinabile internamente

EDOL2

- 2 ingressi per comando di marcia
- 2 ingressi per comando di arresto minimo livello
- 2 uscite motori: Contattori in AC3

EDOL3

- 3 ingressi per comando di marcia
- 3 ingressi per comando di arresto minimo livello
- 3 uscite Motori: Contattori in AC3

EDOLSERIES

- Main switch with door interlock
- Protection fuses
- Transformer 230-400/24V for auxiliary circuits
- 1 input for start command
- 1 input for stop command for minimum level
- Selector AUTO-0-MAN (man stable)
- Blue LED for power on
- Green LED for motor operating
- Red LED for motor protection alarm
- Line contactor AC3
- Overload thermal relay internally restorable

EDOL2

- 2 inputs for start command
- 2 inputs for stop command for minimum level
- 2 outputs: Contactors in AC3

EDOL3

- 3 inputs for start command
- 3 inputs for stop command for minimum level
- 3 outputs: Contactors in AC3

SÉRIE EDOL

- Sectionneur général avec verrouillage de porte
- Fusibles de protection
- Transformateur 230-400/24V circuits auxiliaires
- 1 entrée pour command de démarrage
- 1 entrée pour la commande d'arrêt niveau min.
- Sélecteur AUTO-0-MAN (manuel stable)
- LED bleu de présence réseau
- LED vert de moteur en fonction
- LED rouge d'alarme moteur en protection
- Contacteur de ligne AC3
- Relais thermique de surcharge à rétablissement manuel

EDOL2

- 2 entrées pour command de démarrage
- 2 entrées pour la commande d'arrêt niveau min.
- 2 sorties moteur: Contacteurs en AC3

EDOL3

- 3 entrées pour command de démarrage
- 3 entrées pour la commande d'arrêt niveau min.
- 3 sorties moteurs: Contacteurs en AC3

PHASE	MODEL	POWER		AMPERE	DIMENSIONS*			WEIGHT*	BOX MATERIAL
		KW	HP		L	W	H	KG	
1X230v	EDOL 1-M/0,5	0.37	0.5	3.4 – 5.5	340	240	170	4	P
	EDOL 1-M/1	0.75	1	5.3 – 8.5	340	240	170	4	P
	EDOL 1-M/1,5	1.1	1.5	7.6 – 12	340	240	170	5	P
	EDOL 1-M/2	1.5	2	11 – 15	340	240	170	5	P
	EDOL 1-M/3	2.2	3	14 - 19	340	240	170	5	P
3X400V	EDOL 1-T/0,5	0.37	0.5	0.8 – 1.3	340	240	170	4	P
	EDOL 1-T/0.75	0.55	0.75	1.3 – 2.1	340	240	170	4	P
	EDOL 1-T/1,5	0.75 – 1.1	1 – 1.5	2.1 – 3.4	340	240	170	4	P
	EDOL 1-T/2	1.5	2	3.4 – 5.5	340	240	170	4	P
	EDOL 1-T/3	2.2	3	5.3 – 8.5	340	240	170	4	P
	EDOL 1-T/5.5	4	5.5	7.6 – 12	340	240	170	5	P
	EDOL 1-T/7.5	5.5	7.5	11 – 15	340	240	170	5	P
	EDOL 1-T/10	7.5	10	14 – 19	340	240	170	5	P
	EDOL 1-T/12.5	9.2	12.5	17 – 21	340	240	170	6	P
	EDOL 1-T/15	11	15	20 – 27	420	300	150	12	P
	EDOL 1-T/20	15	20	27 – 32	420	300	150	12	P
	EDOL 1-T/25	18.5	25	30 – 42	530	400	230	15	M
	EDOL 1-T/35	22-26	30 – 35	39 – 55	530	400	230	15	M
EDOL 1-T/40	30	40	51 – 69	530	400	230	15	M	

*dimensioni per quadri per 1 pompa. I quadri con 2 o 3 pompe hanno dimensioni maggiori / sizes for boxes for 1 pump. Boxes for 2 or 3 pumps have bigger sizes / dimensions pour tableaux pour 1 pompe. Les tableaux pour 2 ou 3 pompes ont dimensions majeurs

QUADRO DI CONTROLLO ELETTROMECCANICO PER AVVIO AD INVERTER SERIE EASY INVERTER
ELECTROMECHANICAL CONTROL BOX WITH INVERTER STARTING SERIES EASY INVERTER
TABLEAU DE CONTROLE ELECTROMECHANIQUE POUR DEMARRAGE A INVERTER SERIE EASY INVERTER



SERIE EASY INVERTER

- Sezionatore generale con bloccaporta
- Fusibili di protezione
- Trasformatore 400+230/24V per circuiti ausiliari
- 1 ingresso per comando di arresto minimo livello
- 1 ingresso per comando di marcia con selettore di funzionamento in manuale
- 1 ingresso analogico 4-20mA (0-10V su richiesta)
- 1 Selettore AUTO-0-MAN (manuale stabile)
- Kit ventilazione forzata
- Inverter di Frequenza dotato delle seguenti funzioni:
 - display LCD alfanumerico retroilluminato
 - menù di programmazione funzioni
 - visualizzazione tensione rete, corrente, potenza attiva e apparente per ogni fase, $\cos\phi$, Kwh
 - lista cronosequenziale degli eventi
 - orologio datario con batteria tampone
 - rampe di accelerazione e decelerazione con controllo di coppia regolabili da tastiera
 - regolazione del "pid" per modificare la risposta di velocità e regolazione del sistema in funzione dell'impianto - desiderato
 - controllo remoto a PC con connessione RS232/RS485
 - protezioni mancanza fase, minima e massima tensione, sequenza fasi

EASY INVERTER SERIES

- Main switch with door interlock
- Protection fuses
- Transformer 400+230/24V for auxiliary circuits
- 1 input for stop command for minimum level
- 1 input for start command with selector in manual position
- 1 analog 4÷20 mA input (0-10V on demand)
- 1 selector for AUTO-0-MAN (manual stable)
- Forced ventilation kit
- Electronic frequency inverter with the following functions:
 - back-lighted LCD
 - set up menu: functions
 - visualization of main voltage, current, active and apparent power for each phase, $\cos\phi$, Kwh
 - chronosequential list of the events
 - clock datary with buffer battery
 - acceleration and deceleration ramps with torque control adjustable from keyboard
 - set up time of acceleration and deceleration "PID" (Proportional Integrated Derivated) set up
 - remote control by pc connection RS232/RS485
 - phase failure protection, min/max voltage protection, phase-sequence protection

SÉRIE EASY INVERTER

- Sectionneur général avec verrouillage de porte
- Fusibles de protection
- Transformateur 400+230/24V circuits auxiliaires
- 1 entrée pour la commande d'arrêt niveau min.
- 1 entrée pour command de démarrage avec sélecteur en position manuelle
- 1 entrée analog. 4÷20 mA (0-10V sur demande)
- 1 sélecteur AUTO-0-MAN (manuel stable)
- Kit de ventilation forcée
- Variateur de fréquence électronique avec les suivantes fonctions:
 - écran rétroéclairé
 - menu de programmation des fonctions
 - affchage de la tension, courant, puissance active et apparent pour chaque phase, $\cos\phi$, Kwh
 - liste séquence chronologique des événements
 - horloge calendrier avec batterie en tampon
 - rampes de accélération et de décélération avec contrôle de couple réglable via clavier
 - ajustement du "pid" pour changer la réponse de vitesse et ajustement du système en fonction d'usine souhaité
 - contrôle éloigné connexion RS232 avec ordnat.
 - protection en absence de phase, min et max tension, séquence des phases

EASY INVERTER 2/EASY INVERTER 3

- INVERTER2: uscite 1 velocità variab.+1 velocità fissa
- INVERTER3: uscite 1 velocità variab.+2 velocità fissa

EASY INVERTER 2/EASY INVERTER 3

- INVERTER2: outputs 1 variable speed +1 fixed speed
- INVERTER3: outputs 1 variable speed +2 fixed speed

EASY INVERTER 2/EASY INVERTER 3

- INVERTER2: sorties 1 vitesse variab. +1 vitesse fixe
- INVERTER3: sorties 1 vitesse variab. +2 vitesse fixe

PHASE	MODEL	POWER		AMPERE	DIMENSIONS*			WEIGHT*	BOX MATERIAL
		KW	HP		L	W	H	KG	
3X400V	EASY INVERTER 1/1.5	1.1	1.5	1 – 3.6	530	400	230	16	M
	EASY INVERTER 1/2	1.5	2	1.5 – 4.5	530	400	230	16	M
	EASY INVERTER 1/3	2.2	3	2 – 6.2	530	400	230	16	M
	EASY INVERTER 1/4	3	4	2.5 – 8	530	400	230	16	M
	EASY INVERTER 1/5.5	4	5.5	3 – 9.7	530	400	230	16	M
	EASY INVERTER 1/7.5	5.5	7.5	4 – 13.8	530	400	230	18	M
	EASY INVERTER 1/10	7.5	10	5 – 17.2	530	400	230	18	M
	EASY INVERTER 1/15	11	15	7.5 – 25.4	530	400	230	20	M
	EASY INVERTER 1/20	15	20	10.5 – 34.1	730	500	280	25	M
	EASY INVERTER 1/25	18.5	25	12.5 – 41.8	730	500	280	25	M
EASY INVERTER 1/30	22	30	14.5 – 48.4	730	500	280	30	M	
EASY INVERTER 1/40	30	40	11 - 62	1030	800	330	50	M	

*dimensioni per quadri per 1 pompa. I quadri con 2 o 3 pompe hanno dimensioni maggiori / sizes for boxes for 1 pump. Boxes for 2 or 3 pumps have bigger sizes / dimensions pour tableaux pour 1 pompe. Les tableaux pour 2 ou 3 pompes ont dimensions majeurs

INVERTER VASCO
VASCO INVERTERS
INVERTER VASCO



Inverter da installare a bordo motore o a parete. Regolazione tramite sensore di pressione. Possibilità di collegare fino a 8 dispositivi per funzionamento in parallelo.

Inverter to be installed on the motor or on the wall. Regulation by pressure sensor. Possibility to connect up to 8 devices for parallel operation.

Inverter à installer sur le moteur ou au mur. Régulation par capteur de pression. Possibilité de connecter jusqu'à 8 appareils pour un fonctionnement en parallèle.

DATI TECNICI

- Frequenza d'alimentazione di rete: 50-60 Hz (+/-2%)
- Max. temperatura ambiente di lavoro al carico nominale: 40°C
- Output digitali configurabili N.A o N.C.:
- segnale di marcia motore
- segnale di allarme
- comando pompa DOL 1
- comando pompa DOL 2
- Input analogici, (10 o 15 Vdc) 4-20 mA
- Input digitali, configurabili N.A o N.C., per avvio ed arresto motore
- Seriale RS485

GENERAL CHARACTERISTICS

- Rated frequency : 50 - 60 Hz (+/- 2%)
- Max. working temperature : 40°C
- Settable digital outputs : N.O. or N.C.
- Motor run signal
- Alarm signal
- DOL 1 pump signal
- DOL 2 pump signal
- Analog inputs, (10 or 15 Vdc) 4-20 mA
- 4 digital inputs, settable as N.O or N.C., for motor run/stop
- RS485 serial

DONNÉES TECHNIQUES

- Fréquence d'alimentation du réseau : 50-60 Hz (+/-2%)
- Température maximum de l'environnement de travail avec charge nominale : 40°C (104 °F)
- Sortie numérique à configurer N.O. ou N.F. :
- signal de marche du moteur
- signal d'alarme
- commande pompe DOL 1
- commande pompe DOL 2
- entrée analogique, (10 ou 15 Vcc) 4-20 mA
- 4 entrées numériques configurables N.O. ou N.F., pour le démarrage et l'arrêt du moteur
- Sérial RS485

MOD.	Vin [+/- 15%]	max Vout	max Iout	P2 motore tipica	Dimensioni	
	[V]		[A]	[kW]	[mm]	
VASCO 209	1 x 230	1 x Vin	9	1,1	181x181x228 IP55	
		3 x Vin	7	1,5		
VASCO 214	1 x 230	1 x Vin	9	1,1		
		3 x Vin	11	3		
VASCO 306	3 x 230	3 x Vin	6	1,1		
VASCO 309	3 x 230	3 x Vin	9	2,2		
VASCO 406	3 x 380 - 460	3 x V in	6	2,2		
VASCO 409	3 x 380 - 460	3 x V in	9	4		
VASCO 218	1 x 230	3 x V in	18	4		260x260x180 IP 55
VASCO 225	1 x 230	3 x V in	25	5,5		
VASCO 314	3 x 230	3 x V in	14	3		
VASCO 318	3 x 230	3 x V in	18	4		
VASCO 325	3 x 230	3 x V in	25	5,5		
VASCO 330	3 x 230	3 x V in	30	7,5		
VASCO 414	3 x 380 - 460	3 x V in	14	5,5		
VASCO 418	3 x 380 - 460	3 x V in	18	7,5		
VASCO 425	3 x 380 - 460	3 x V in	25	11		
VASCO 425	3 x 380 - 460	3 x V in	30	15		
VASCO 338	3 x 230	3 x V in	38	9,2	410x680x260 IP54	
VASCO 348	3 x 230	3 x V in	48	11		
VASCO 365	3 x 230	3 x V in	65	15		
VASCO 375	3 x 230	3 x V in	75	18,5		
VASCO 385	3 x 230	3 x V in	85	22		
VASCO 438	3 x 380 - 460	3 x V in	38	18,5		
VASCO 448	3 x 380 - 460	3 x V in	48	22		

BASI E PORTAQUADRI
BASES AND PANEL HOLDERS
BASAMENTS ET SUPPORT TABLEAU



MOD.	mm			KG
	A	B	C	
SKID 1	50	520	245	3,5
SKID 2	60	615	320	7
SKID 3	60	700	500	16
SKID 4	50	280	245	1,5
PIAS1	-	190	270	0,7
PIAS2	-	310	370	0,8
AST1	40	-	480	0,7
AST2	60	-	630	1

① SKID 1-2-3
 ② SKID 4
 ③ PIAS 1-2
 ④ AST 1-2









COLLETTORI
MANIFOLDS
COLLECTEURS







MOD.	In	In	mm			KG
			A	B	C	
OUTLET1	1,5"	1"	500	300	370	2
OUTLET2	2"	1,25"	500	300	370	2,5
OUTLET3	2,5"	1,25"	500	300	370	3
OUTLET4	2"	1,25"	700	360	370	3
OUTLET5*	3"	1,5"	700	360	370	13
OUTLET6*	2,5"	1,5"	500	300	370	3
INLET1	1,5"	1,5"	500	300	-	2
INLET2	2"	1"	500	300	-	2
INLET3	2,5"	1,5"	500	300	-	3
INLET4	3"	2"	700	360	-	5,5
INLET5*	4"	2"	700	360	-	16

* flangiato / flanged / bridée

VALVOLAME
FITTINGS
RACCORDS

	DESCRIZIONE DESCRIPTION DESCRIPTION	MISURE SIZES MEASURES
	Valvole di non ritorno Check valves Clapet de non retour	0,5" – 1" – 1,25" – 1,5" – 2" – 2,5" – 3" – 4"
	Valvole a sfera Ball valves Vannes à boisseau sphérique	1" – 1,25" – 1,5" – 2"
	Attacchi MF con bocchettone MF connections with union Connexions MF avec le syndicat	1" – 1,25" – 1,5" – 2"
	Manometri Pressure gauges Manometres	D. 50 radial conn 0,25" (0-6, 0-10, 0-16 bar) D. 63 radial conn. 0,25" (0-6, 0-10, 0-16 bar) D. 50 back conn 0,25" (0-6, 0-10, 0-16 bar) D. 63 back conn. 0,25" (0-6, 0-10, 0-16 bar)
	Nipples Nipples Nipples	1" x 0,25" – 1,25" x 0,25" – 1,5" x 0,25", 2" x 0,25"
	Nipplo doppio Double nipples Nipples double	1" – 1,25" – 1,5" – 2"
	3 way H 71 4 way H 72 5 way H 71 5 way H91	
	Valvole di intercettazione a farfalle Butterfly shut-off valves Vannes d'arrêt papillon	DN 50-65-80-100 DN 100 – 125 – 200 – 250 DN 300 – 350 - 400
	Valvole di intercettazione flangiata Flanged shut-off valves Vannes d'arrêt bridés	DN 50-65-80-100 DN 100 – 125 – 200 – 250 DN 300 – 350 - 400

ALTRI
OTHERS
AUTRES

	DESCRIZIONE DESCRIPTION DESCRIPTION	MISURE SIZES MEASURES
	Vasi a membrana Pressure tank with membrane Vaisseaux à membrane	8-18-20-24 LT SPHERICAL 20-24-50-60-100-200-300 LT HOR 20-24-50-60-100 VERTICAL 200-300-500 VERTICAL
	Alimentatore d'aria Air feeders Alimentateurs d'air	100-500 600-1000
	Pressostati Pressure gauges Interrupteurs de pression	PM/PT5 1-5BAR PM/PT12 3-12 BAR KP36 2-14 BAR
	Trasduttore di pressione Pressure trasducer Trasdcteur de pression	0-10 bar 0-16 bar 0-25 bar
	Interruttori a galleggiante Float switches Flotteurs	Clean 2-5-10 mt H05 Clean 2-5-10 mt H07RNF Taurus 10 mt

STAC SRL

Via Fabio Severo 19
34133 Trieste – Italy
Tel. +39 040 361811 / 364486
www.stac-ts.com
info@stac-ts.com